

Woodcutting Guides

Woodcutting guides can be used with all widths of blades. To set guides slacken the thumb screws (item 107) and pull fibre blocks outwards. Tension and track saw blade. Adjust guides so that thrust rollers come into contact with back edge of saw blade and tighten locking screws on tool post and tilt cradle. Slacken off thumb screw (item 102) and adjust guide bodies until front face of fibre blocks are just behind saw teeth, tighten screws. Adjust fibre blocks so they support saw blade but do not grip it, and tighten screws. These guides use standard location points.

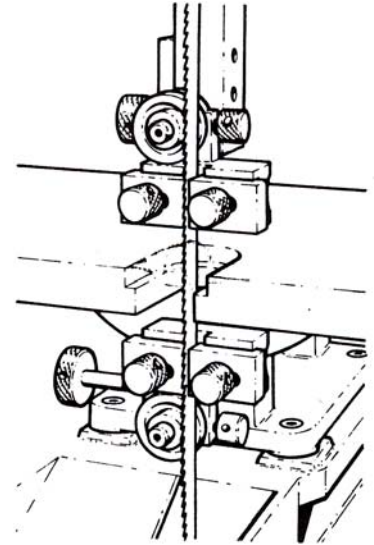

ITEM	PART NO.	DESCRIPTION	QTY
	SM315	Woodcutting blade guide- Upper	1
	SM325	Woodcutting blade guide- Lower	1
100	2619	Support Arm- Upper	1
101	2643	Guide Body- Upper	1
102	2535	Thumb Screw	2
103	SM322	Thrust Roller Assembly (with 104)	2
104	BO5480	Screw	2
105	2624	Guide Block	4
106	BO5914	Washer	4
107	2621	Thumb Screw	4
108	2644	Guide Body- Lower	1
109	2645	Support Arm- Lower	1

Items 102-107 common to SM315 & SM325
Quantities shown are for both assemblies

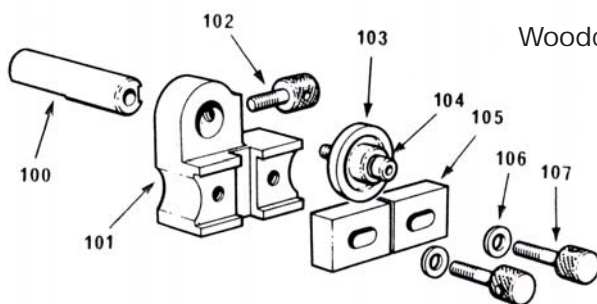

Woodcutting Blade Guides- Upper.- SM315

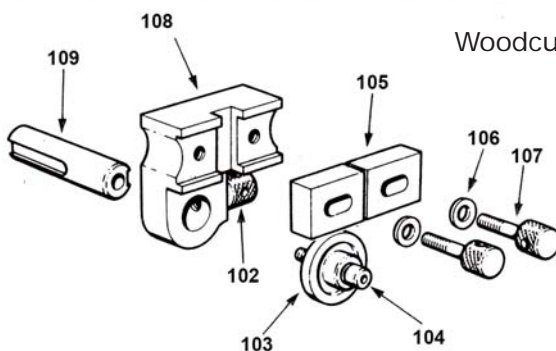

Woodcutting Blade Guides- Lower.- SM325

MACHINE SPARES LTD.

Garratt St. Brierley Hill, West Midlands, DY5 1JU.

Tel: 0870 870 2550 fax: 0870 870 2660